

Tools Needed

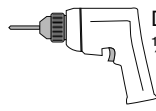

Drill Bits Needed:
1/8", 7/8", 1"

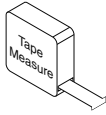
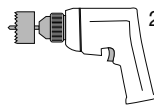

2 1/8" Hole Saw

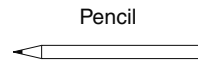

Pencil



Chisel

1 Measure Door Width

If the door is thinner than 1 3/8" or thicker than 1 3/4", then the lock will not fit properly on the door.

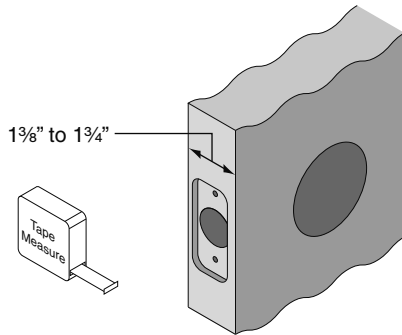

4 If Needed, Enlarge Hole in Door

If hole in door is smaller than 2 1/8", then use 2 1/8" hole saw to enlarge hole.

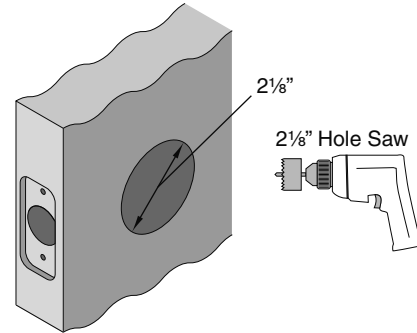

2 Measure for Backset

If existing backset is not 2 3/8" or 2 3/4", then the lock will not fit properly on the door.

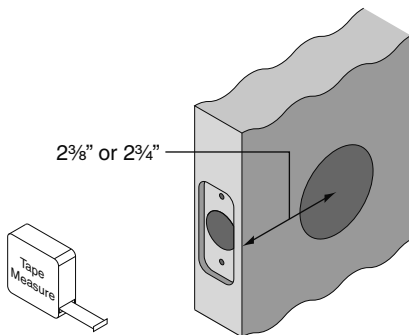

5 If Needed, Enlarge Hole in Door Edge

If hole in door edge is smaller than 7/8", then use 7/8" or 1" drill bit to enlarge hole.

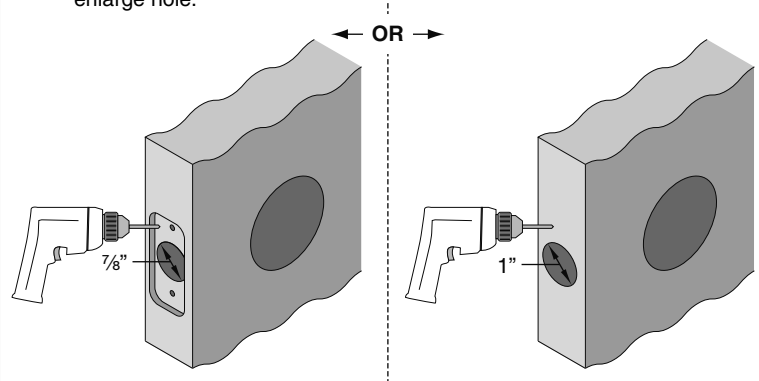

3 Measure Hole Sizes

If hole sizes are larger than those shown, then the lock will not fit properly on the door.

If hole sizes are smaller than those shown, see steps 4 and 5.

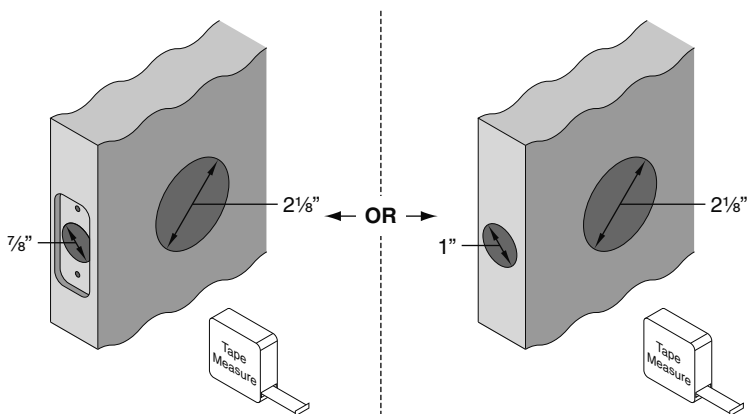

6 Check Strike (Door Jamb) Preparation

- Place new strike against door jamb.
- If strike does not fit properly, use pencil to trace around strike and mark hole positions.
- If needed, use chisel and drill to correct door jamb preparation.

