

Tools Needed

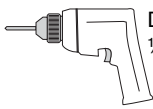

Drill Bits Needed:
1/8", 7/8", 1"

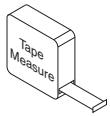
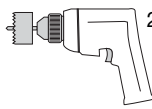

Pencil



Chisel



1 Measure Door Width

If the door is thinner than 1 3/8" or thicker than 1 3/4", then the lock will not fit properly on the door.

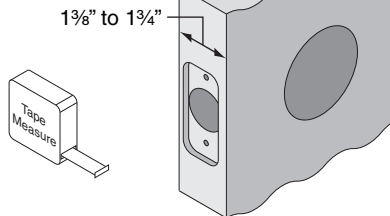

2 Measure for Backset

If existing backset is not 2 3/8" or 2 3/4", then the lock will not fit properly on the door.

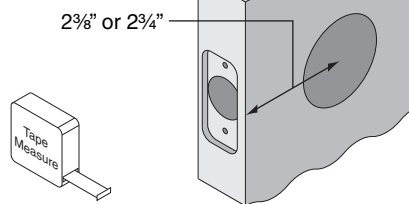

3 Measure Hole Sizes

If hole sizes are larger than those shown, then the lock will not fit properly on the door. If hole sizes are smaller than those shown, see steps 4 and 5.

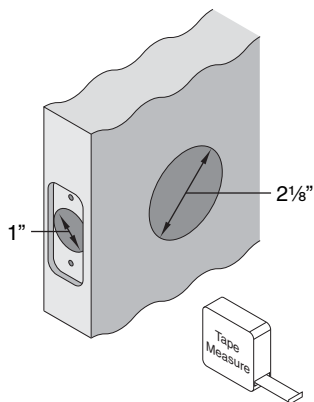

4 If Needed, Enlarge Hole in Door

If hole in door is smaller than 2 1/8", then use 2 1/8" hole saw to enlarge hole.

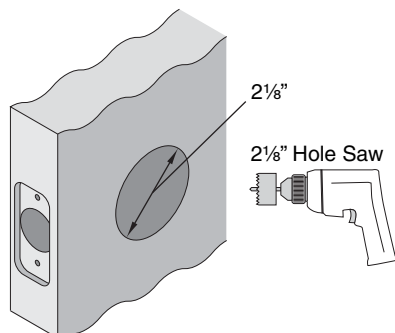

5 If Needed, Enlarge Hole in Door Edge

If hole in door edge is smaller than 1", then use 1" drill bit to enlarge hole.

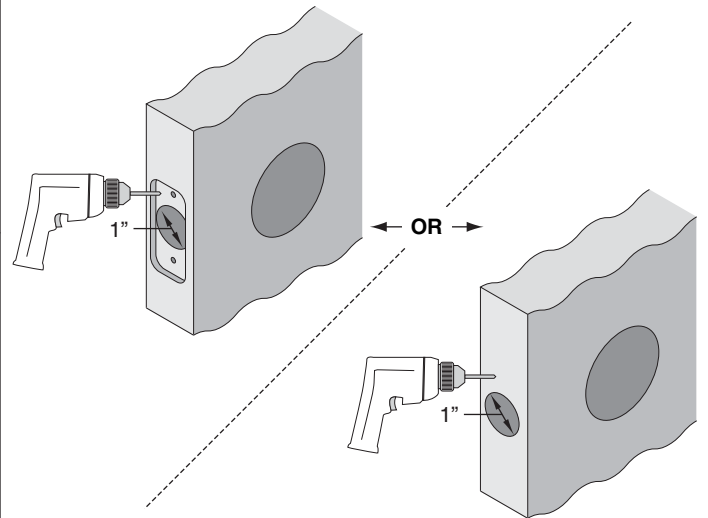

6 Check Strike (Door Jamb) Preparation

- Place new strike box and strike against door jamb.
- If strike box and strike do not fit properly, use pencil to trace around strike box and strike and mark hole positions.
- If needed, use chisel and drill to correct door jamb preparation.

